

OVERHEAD HOLDERS OR STOPS MUST BE INSTALLED BEFORE CLOSERS.

1. A. DETERMINE THE MOUNTING BEING USED FROM THE ILLUSTRATIONS BELOW.
- B. SELECT MOUNTING GROUP NUMBER FROM THE CHART BELOW. MOST CONTINUOUS HINGES ARE GROUPED WITH 4 1/2" WIDE BUTT OR 4 1/2" SWING CLEAR HINGE.
- C. USING THE MOUNTING GROUP NUMBER AND THE OVERHEAD HOLDER OR STOP SIZE AND THE DEGREE OF OPENING DESIRED, FIND "A", "B", AND "C" DIMENSIONS FROM THE CHART ON PAGE 3. FOR DEAD STOP ADD 9/16" (14mm) TO THE "A" DIMENSION FROM THE CHART. SEE NOTE D FOR INFORMATION ABOUT DEAD STOP.

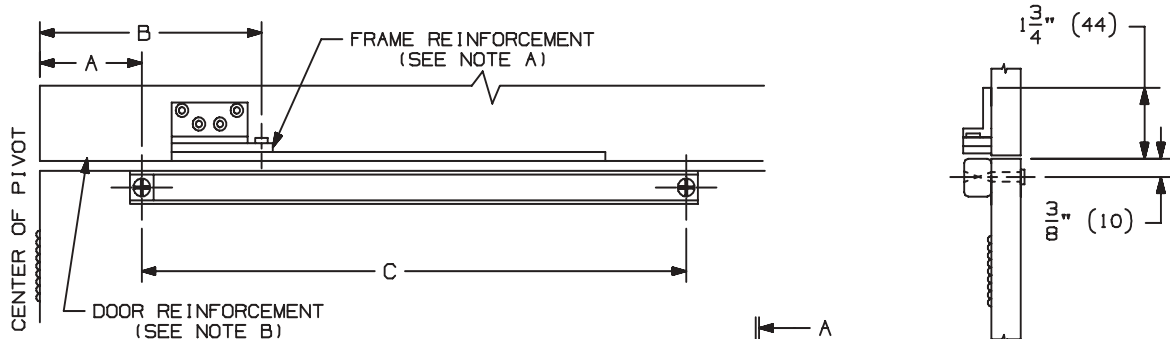

**NOTES:**

- A. HOLLOW METAL FRAMES SHOULD BE PROPERLY REINFORCED WITH A 3/16" (5) MINIMUM THICKNESS BY 12" (305) MINIMUM WIDTH PLATE.
- B. HOLLOW METAL DOORS SHOULD BE PROPERLY REINFORCED WITH A 3/16" (5) MINIMUM THICKNESS PLATE BY 2 1/2" (64) MINIMUM WIDTH PLATE.
- C. STOP ONLY UNITS ARE PERMITTED ON MANY FIRE DOOR APPLICATIONS. HOWEVER, MECHANICAL HOLD-OPEN DEVICES THAT REQUIRE MANUAL RELEASE ARE NOT PERMITTED FOR USE ON ANY FIRE DOOR AS OUTLINED ON NFPA80® OF NFPA101®. CONTACT GLYNN-JOHNSON OR YOUR LOCAL REPRESENTATIVE FOR ASSISTANCE.
- D. DEAD STOP (DS) TEMPLATING MAY BE USED ON HOLD-OPEN, FRICTION STOP AND STOP ONLY MODELS, BUT SHOULD NOT BE USED ON "SE" MODELS. THE DS POSITION IS REACHED WHEN THE SHOCK SPRING IS FULLY COMPRESSED. WHEN DS TEMPLATING IS USED, THE INITIAL DEGREE OF STOP WILL BE 5° -7° LESS THAN THE DS OPENING. FOR USE ON DOORS OPENING BACK TO BACK, AGAINST A WALL OR OBSTRUCTION.

**450 ADJUSTMENTS:**

**HOLD-OPEN TENSION ADJUSTMENT (HOLD-OPEN UNIT ONLY)**  
 USING A PHILLIPS SCREWDRIVER, TURN SCREW IN THE END OF SLIDER CLOCKWISE TO INCREASE THE HOLD-OPEN TENSION AND COUNTERCLOCKWISE TO DECREASE THE HOLD-OPEN TENSION.

**FRICTION TENSION ADJUSTMENT (FRICTION UNIT ONLY)**  
 USING A 3/32" ALLEN WRENCH, TURN SET SCREW IN THE MIDDLE OF THE SLIDER CLOCKWISE TO INCREASE THE FRICTION TENSION AND TURN COUNTERCLOCKWISE TO DECREASE THE FRICTION TENSION.

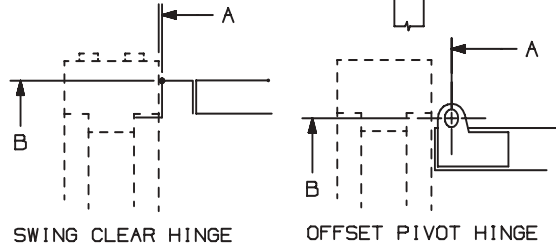

DOOR THICKNESS	HINGE & TYPE SHOWN	MOUNTING GROUP
1 3/8" (35mm)	3 1/2" BUTT	2
	3/4" OFFSET PIVOT	2
1 3/4" (44mm)	4" WIDE BUTT	1
	4 1/2" WIDE BUTT	1
	3/4" OFFSET PIVOT	2
	4 1/2" SWINGCLEAR	1
	5" SWINGCLEAR	2
2" (51mm)	4 1/2" WIDE BUTT	1
	5" WIDE BUTT	2
	3/4" OFFSET PIVOT	2
	4 1/2" SWINGCLEAR	1
	5" SWINGCLEAR	2
	SOSS 220	1
2 1/4" (57mm)	5" WIDE BUTT	1
	4 1/2" SWINGCLEAR	1
	SOSS 220	1

SCREW DETAILS			
	QTY	WOOD	METAL
ANGLE	4	10-32 x 1/2" FPHMS	10-32 x 1/2" FPHMS
JAMB	4	#10 x 1 1/2" FPHSMS	10-32 x 1/2" FPHMS
DOOR	2	10-24 x 1 1/2" PPHMS	10-24 x 1 1/2" PPHMS
	2	10-24 x 1 9/16" SEX BOLT	10-24 x 1 9/16" SEX BOLT

450 SERIES SURFACE OVERHEAD HOLDER HINGE (PULL SIDE) INSTALLATION TEMPLATE



NOTE: DIMENSIONS IN ( ) ARE IN MILLIMETERS

TEMPLATE INST. 450JP.PG 1-1 NUMBER:

DATE: 04-15-04

INST.450JP ①

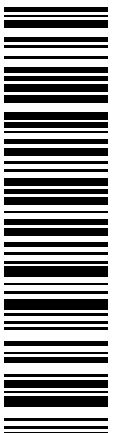

2. A. LOCATE "B" DIMENSION ON THE FACE OF THE FRAME. NOTE THAT THE "B" DIMENSION IS MEASURED FROM THE CENTERLINE OF THE HINGE AS SHOWN.
- B. FOR METAL FRAMES, USE #21 DRILL AND 10-32 TAP IN 4 PLACES. FOR WOOD FRAMES DRILL 1/8" PILOT HOLES IN 4 PLACES. MOUNTING HOLES SHOULD BE PREPARED IN THE FIELD.

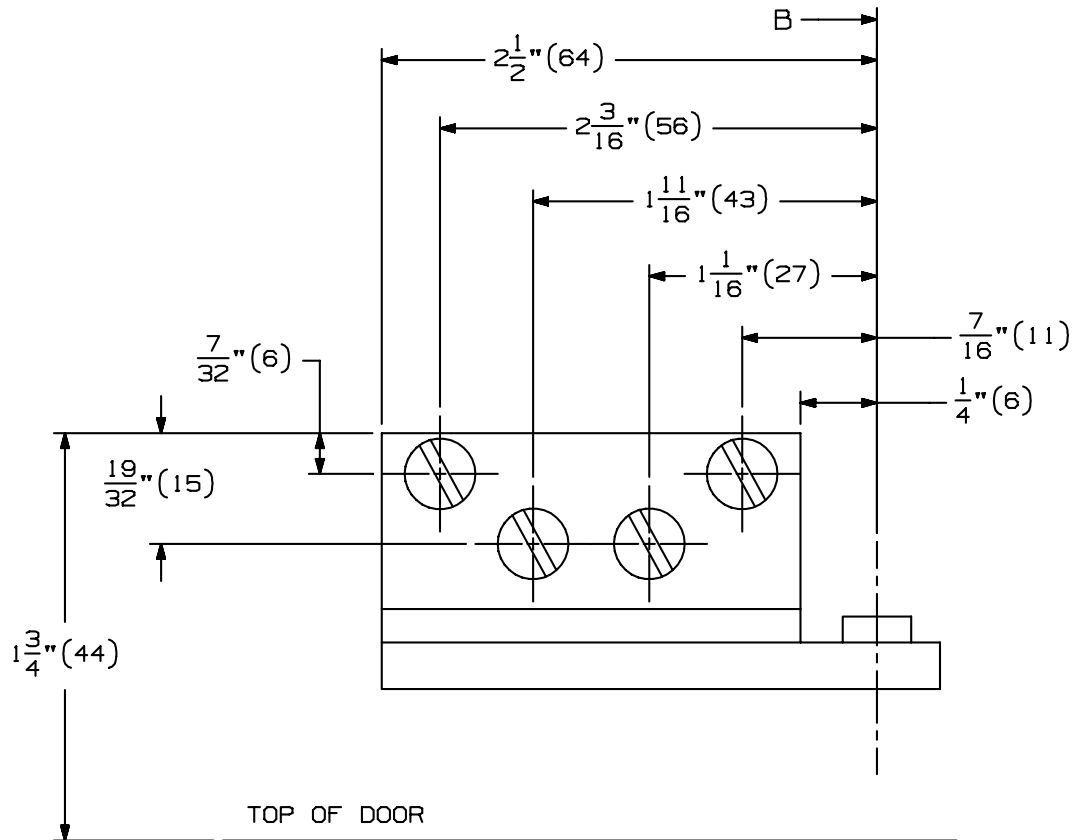

3. A. LOCATE "A" & "C" DIMENSION ON THE DOOR. NOTE THAT THE "A" DIMENSION IS MEASURED FROM THE CENTERLINE OF HINGE AS SHOWN.
- B. DRILL THE 1/4" (6) DIAMETER THROUGH HOLES DOWN 3/8" (10) FROM THE TOP OF THE DOOR IN TWO PLACES. ON THE PULL SIDE OF DOOR, DRILL 13/32" (10) DIAMETER HOLE, 1 5/8" (41) DEEP FOR SEX BOLT. MOUNTING HOLES SHOULD BE PREPARED IN THE FIELD.
4. A. INSTALL ANGLE BRACKET ONTO STANDARD JAMB BRACKET WITH 10-32 x 1/2" FPHMS PROVIDED WITH THE ANGLE BRACKET.
- B. INSTALL THE CHANNEL ON THE DOOR WITH THE SHOCK SPRING TOWARDS THE HINGE EDGE OF DOOR.
- C. INSTALL THE ANGLE BRACKET TO THE FACE OF THE FRAME.

450 SERIES SURFACE OVERHEAD  
HOLDER HINGE (PULL SIDE)  
INSTALLATION TEMPLATE

**IR** GLYNN-JOHNSON®

NOTE: DIMENSIONS IN ( ) ARE IN MILLIMETERS

TEMPLATE INST. 450JP.PG2\_1  
NUMBER:

DATE:  
04-15-04

# MOUNTING GROUPS 1 & 2 450 SERIES SURFACE OVERHEAD STOP & HOLDER

CAUTION: "A" & "B" DIMENSIONS ARE MEASURED FROM THE CENTERLINE OF PIVOT, NOT EDGE OF DOOR  
 FOR DEAD STOP ADD 9/16" (14mm) TO THE "A" DIMENSION \* NOT TO BE USED WITH SWINGCLEAR HINGES  
 FOR SE STOPS USE HOLD-OPEN MOUNTING DIMENSION  
 HO=HOLD-OPEN FOR HOLDERS, OPENING FOR STOPS  
 I=ARM LENGTH FROM PIVOT CENTERLINE TO PIVOT CENTERLINE  
 (FOR REFERENCE ONLY)

DEGREE	85 HO		90 HO		95 HO		100 HO		105 HO		110 HO		C	I	
	A	B	A	B	A	B	A	B	A	B	A	B			
451	IN. 18-23	2 13/16	4 7/8	2 9/16	4 5/8	2 5/16	4 7/16	2 1/8	4 3/16	1 15/16*	4 1/16*	1 3/4*	3 7/8*	14 3/4	8 1/4
	mm 457-584	71	124	65	117	59	113	54	106	49	103	44	98	375	210
452	IN. 23 1/16-27	4 3/16	6 1/8	3 7/8	5 13/16	3 9/16	5 9/16	3 5/16	5 5/16	3 3/16	5	3	14 13/16	16 3/8	10
	mm 585-686	106	156	98	148	90	141	84	135	81	127	76	122	416	254
453	IN. 27 1/16-33	8 1/4	7 7/16	7 13/16	7	7 7/16	6 11/16	7 1/8	6 5/16	6 7/8	6 1/16	6 5/8	5 13/16	17 5/8	14
	mm 687-838	210	189	198	178	189	170	181	160	175	154	168	148	448	356
454	IN. 33 1/16-39	12 1/16	9	11 9/16	8 1/2	11 1/8	8 1/16	10 3/4	7 5/8	10 3/8	7 5/16	10 1/16	7	19 3/8	18
	mm 839-991	306	229	294	216	283	205	273	194	264	186	256	178	492	457
455	IN. 39 1/16-45	15 3/4	10 3/8	15 3/16	9 5/16	14 5/8	9 3/16	14 1/8	8 3/4	13 11/16	8 7/16	13 3/8	8	20 7/8	21 3/4
	mm 992-1143	400	264	386	244	371	233	359	222	348	214	340	203	530	552
451	IN. 18-23	2 3/4	4 7/8	2 1/2	4 9/16	2 5/16	4 5/16	2 1/16	4 3/16	1 15/16*	4*	1 3/4*	3 7/8*	14 3/4	8 1/4
	mm 457-584	70	124	64	116	59	110	52	106	49	102	44	98	375	210
452	IN. 23 1/16-27	4 1/8	6 1/8	3 13/16	5 3/4	3 9/16	5 1/2	3 5/16	5 5/16	3 1/16	5 1/16	2 15/16	4 7/8	16 3/8	10
	mm 585-686	105	156	97	146	90	140	84	135	78	129	75	124	416	254
453	IN. 27 1/16-33	8 1/4	7 5/16	7 13/16	6 7/8	7 7/16	6 1/2	7 1/8	6 1/4	6 13/16	6	6 9/16	5 3/4	17 5/8	14
	mm 687-838	210	186	198	175	189	165	181	159	173	152	167	146	448	356
454	IN. 33 1/16-39	12	9	11 1/2	8 1/2	11 1/16	8	10 11/16	7 9/16	10 5/16	7 1/4	10	7	19 3/8	18
	mm 839-991	305	229	292	216	281	203	271	192	262	184	254	178	492	457
455	IN. 39 1/16-45	15 3/4	10 3/16	15 1/16	9 11/16	14 1/2	9 1/4	14 1/8	8 5/8	13 11/16	8 5/16	13 5/16	8	20 7/8	21 3/4
	mm 992-1143	400	259	383	246	368	235	359	219	348	211	338	203	530	552

MOUNTING GROUP #1

MOUNTING GROUP #2

## 450 SERIES SURFACE OVERHEAD HOLDER HINGE (PULL SIDE) INSTALLATION TEMPLATE



NOTE:

TEMPLATE NUMBER: INST. 450JP.PG3\_1

DATE: 04-15-04